

LED Gas Station Canopy Light

AGS-01-G1



Better solutions for a Led Gas Station Canopy Light

- IP65 water-proof**
 - AC100-277V 50/60Hz**
 - Easy Installation**
 - 140Lm/w**
- Operating Temp.:** -40°C ~ +50°C **Storage Temp.:** -40°C ~ +80°C



Options

Power MEAN WELL DRIVER ELG series A: Standard ELG series B: Dimmable 0-10V ELG series DA: Dimmable DALI	Color 3000K 4000K 5700K
--	---

Application

The LED Gas Station Light provides a energy saving solution to a wide spectrum of applications including, but not limited to security lighting in schools, office complexes, light commercial development, apartments, parking garages, entryways, and stairwells. It also can be used in workshop, warehouse, parking lot, toll gate, gas station, supermarket, exhibition hall, gym and other places.

Specifications

Item	Power	Lumen	Leds	CRI	Weight	Beam Angle
AGS60W-01-G1	60W	8400Lm	LUMILEDS 3030	> 80	7.1kg	80°
AGS80W-01-G1	80W	11200Lm	LUMILEDS 3030	> 80	7.1kg	80°
AGS100W-01-G1	100W	14000Lm	LUMILEDS 3030	> 80	7.4kg	80°
AGS120W-01-G1	120W	16800Lm	LUMILEDS 3030	> 80	7.4kg	80°
AGS150W-01-G1	150W	21000Lm	LUMILEDS 3030	> 80	7.4kg	80°

Dimensions(mm)

Photometry

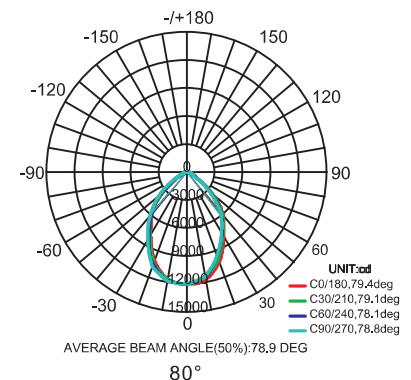
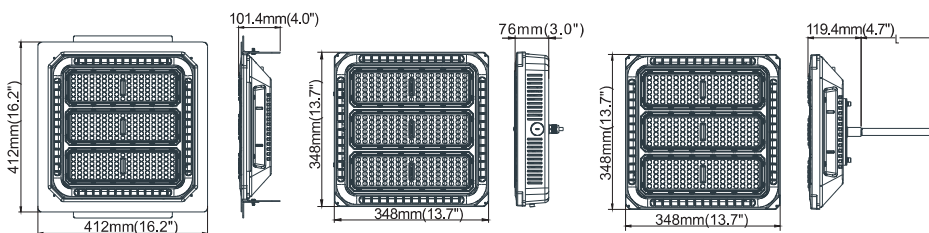

P1 Recessed Installation Frame (Standard)

P2 Surface mounting installation

P3 Pole installation



AGS-01-G1

Model Options



P1 Recessed Installation Frame (Standard)



P2 Surface mounting installation



P3 Pole installation

Installation and use

P1 Recessed Installation Frame (Standard)

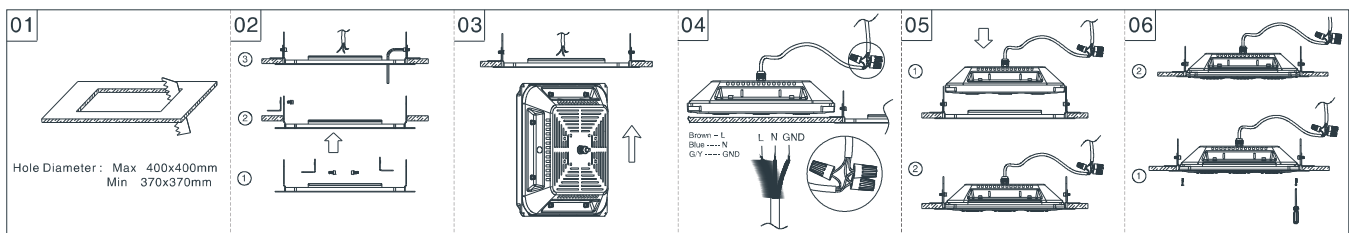

P2 Surface mounting installation

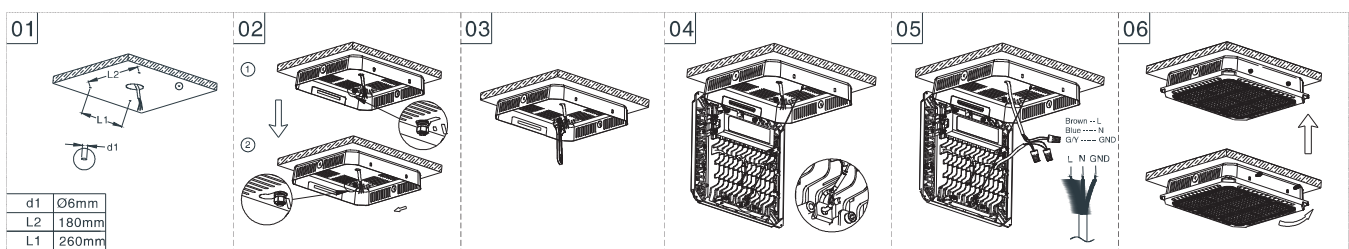

P3 Pole installation

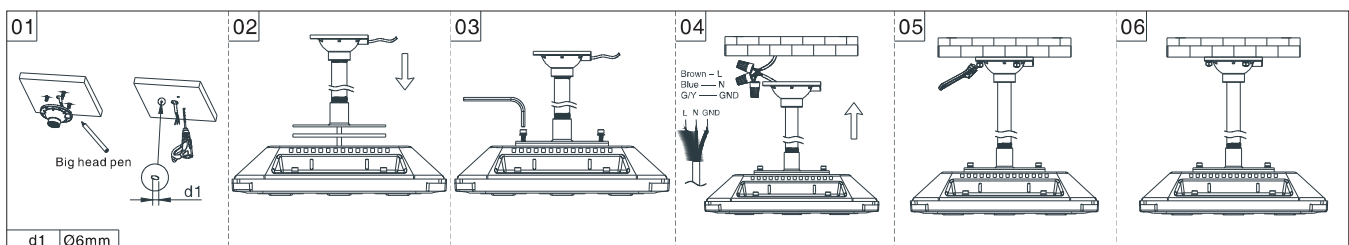

Packing Spec

Item	Box			Carton		
	Measurement(mm)	Gross weight	Pcs/box	Measurement(mm)	Gross weight	Pcs/box
AGS60W~150W-01-G1 (P1 Standard)	L480*W480*H150	8.45kg	1	/	/	/
AGS60W~150W-01-G1 (P2/P3)	L420*W420*H145	8.35kg	1	/	/	/



Lighting

LED Gas Station Canopy Light

AGS-01-G7



Better solutions for Led Gas Station Canopy Light

- IP65 water-proof
- AC100-277V 50/60Hz
- Easy Installation
- 140Lm/w



Operating Temp.: -40°C~+50°C Storage Temp.: -40°C~+80°C

Options

Driver	Voltage	CCT
Sosen Driver	AC100-277V	3000K 4000K 5000K 5700K

Application

The LED Gas Station Light provides a energy saving solution to a wide spectrum of applications including , but not limited to security lighting in schools,office, complexes , light commercial development , apartments , parking garages, entryways,and stairwells. It also can be used in workshop,warehouse,parking lot,toll gate , gas station , supermarket , exhibition hall , gym and other places.

Specifications

Item	Power	Luminous Efficacy	Leds	CRI	Weight	Beam Angle
AG-GS80W-01-G7	80W	140lm/W	Lumileds 2835	> 80	7.80kg(17.2lbs)	30°/60°/90°/150°
AG-GS100W-01-G7	100W	140lm/W	Lumileds 2835	> 80	7.80kg(17.2lbs)	30°/60°/90°/150°
AG-GS120W-01-G7	120W	140lm/W	Lumileds 2835	> 80	7.80kg(17.2lbs)	30°/60°/90°/150°
AG-GS150W-01-G7	150W	140lm/W	Lumileds 2835	> 80	7.80kg(17.2lbs)	30°/60°/90°/150°

Dimensions(mm)

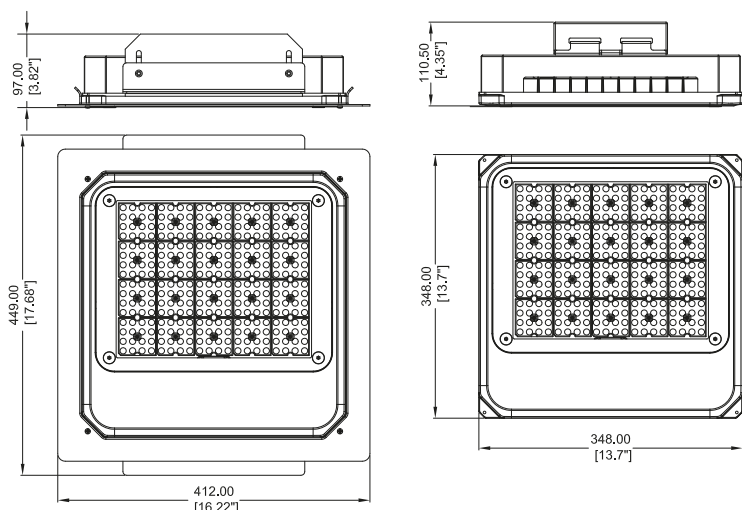

Photometry

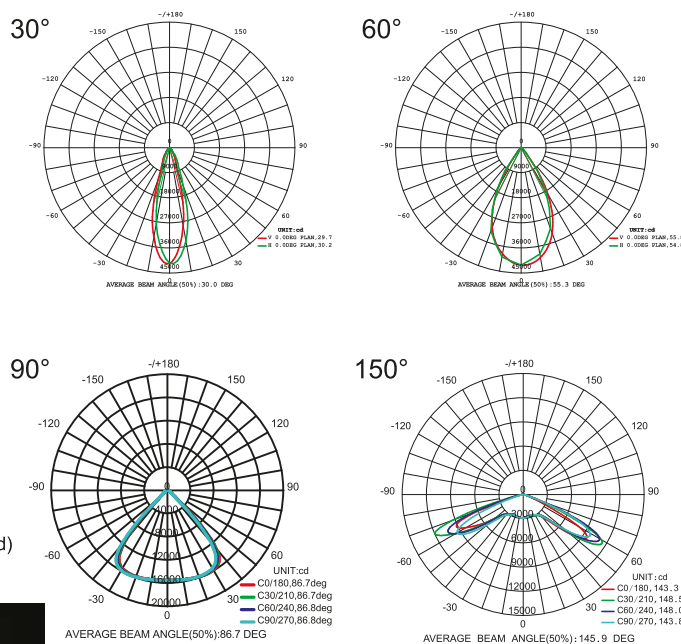

AGS-01-G7 LED Gas Station Canopy Light

Model Options

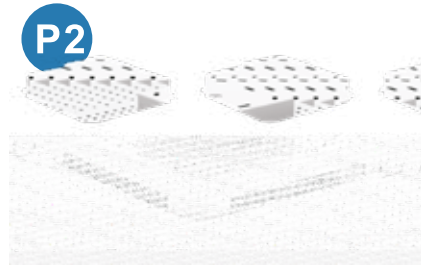

Microwave Motion Sensor Options

(Extra Remote Control Options)
Only for TUV,UL List Driver



Default Setting:
Detection area:100%,
Hold time:5 seconds,
Daylight threshold:50lx,
Stand-by dimming level:50%,
Stand-by period:10 seconds

Installation and use

P1 Recessed Installation Frame

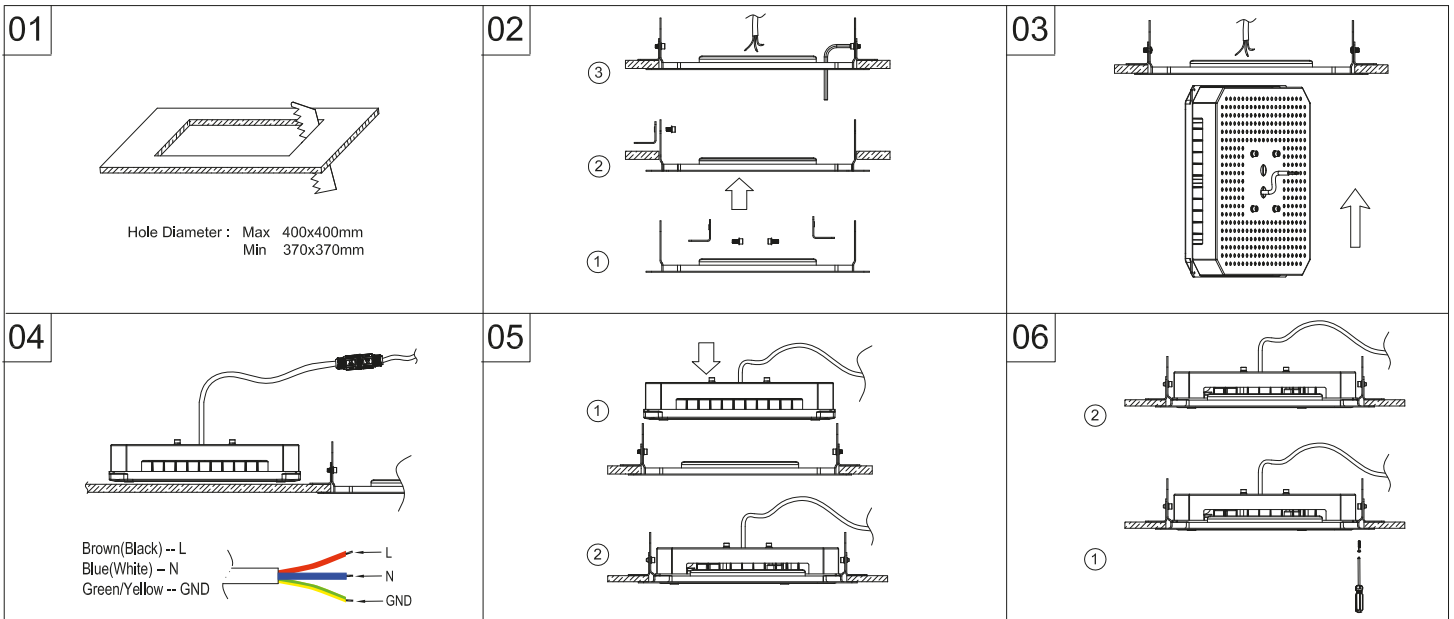

P2 Surface mounting installation(standard)

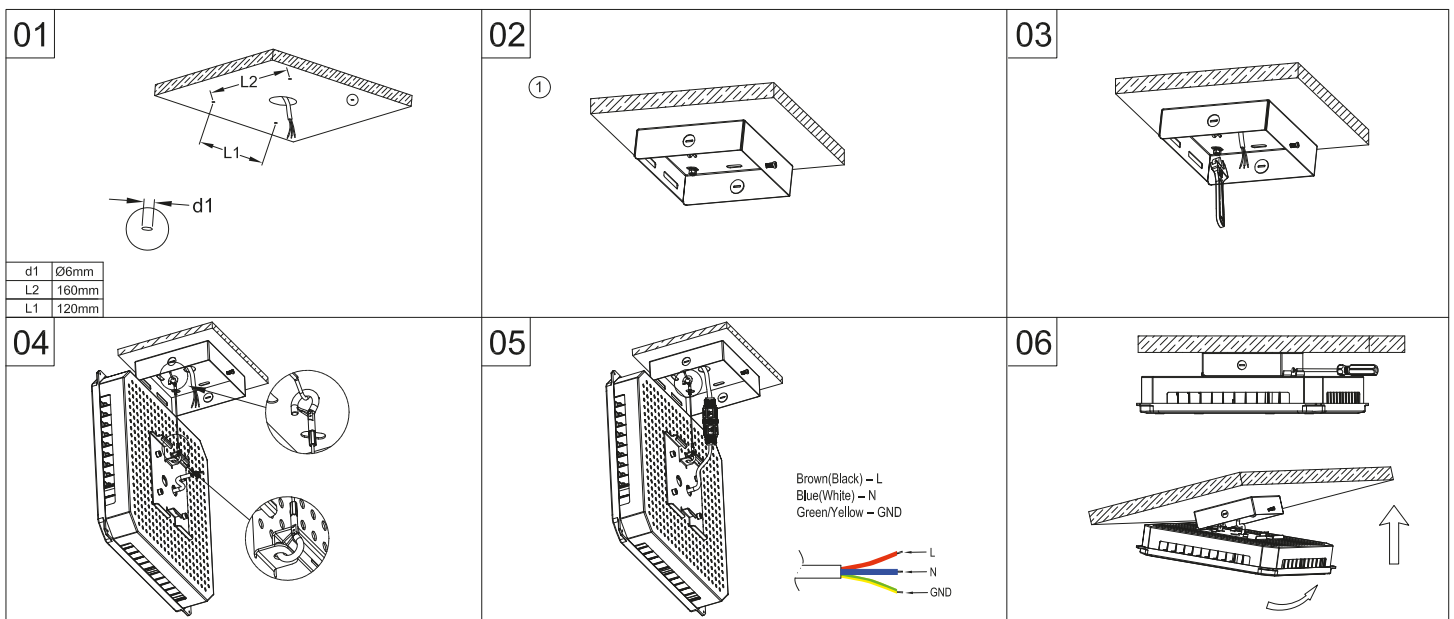

Packing Spec

Item	Box			Carton		
	Measurement(mm)	Gross weight	Pcs/box	Measurement(mm)	Gross weight	Pcs/box
AGS80W~150W-01-G7-P1	L480*W460*H165	9kg(19.8lbs)	1	/	/	/
AGS80W~150W-01-G7-P2	L420*W420*H175	7.5kg(16.5lbs)	1	/	/	/